

SYSTEM FEATURES



- Protects facilities and equipment against the harmful effects of lightning strikes and internally generated electrical transients
- Individually fused MOV's provide superior protection and continuous operation
- 200kAIC short circuit current rating allows direct bus connection without the need of an upstream over-current protection device
- Includes pre-wired pigtail conductors to stream line installation
- NEMA LS1 compliance – single pulse tested at nationally recognized 3rd party lab
- Low profile design has an optional flush-mount plate for in-wall recessed panel applications
- UL 1283 EMI/RFI filter option
- Ultra Compact Footprint – makes installation flexible
- Enhanced Transient Filter for better protection of electronic loads
- 25-Year Unlimited Free Replacement Warranty

PRODUCT SPECIFICATIONS

GENERAL SPECIFICATIONS

Maximum Rated Surge Current: 100kA per phase (50kA/mode)
Repetitive Surge Current Rating: 3,000 impulses per mode based on actual test data (using ANSI/IEEE C62.41.1-2002 C3 combo wave)
Application: ANSI/IEEE C62.41 Location C, B & A. Ideal for distribution panels, branch panels and critical loads
Design: Hybrid parallel design with individual fused MOV's and UL 1283 EMI/RFI filter option
Warranty: 25-Year Unlimited Free Replacement
Safety Listing: UL 1449 2nd Edition 2005 Revision (effective 2/9/2007) and UL 1283

ELECTRICAL SPECIFICATIONS

Modes of Protection: All modes: L-N, L-G, N-G & L-L
Input Power Frequency: 47-63Hz
Connection Method: Parallel to electrical distribution system
Response Time: Less than 0.5 nanoseconds
Standard Monitoring: Status indicator lights (one per phase)
Short Circuit Current Rating: 200 kAIC – no upstream over-current protection device (breaker or fuse) required.

MECHANICAL SPECIFICATIONS

Dimensions (approx.): 6" H x 6" W x 4" D
 (160 mm H x 160 mm W x 102 mm D)
Enclosure: Powder coated, impact-resistance steel, weather-proof NEMA 4 (IP56)
Connection: Pre-wired with 30" (915 mm) of #10 AWG (5.26 mm²) conductor
Mounting: Dual mounting flanges
Operating Environment: -40° C to 70° C (-40° F to 160° F)
 5% to 95% non-condensing humidity
Weight: 10 lbs. (4.5 kg)

AVAILABLE CONFIGURATIONS

Model Number	Description
TK-TT2-100-1P240-FL	240VAC, SinglePhase 2-wire + grd
TK-TT2-100-1S240-FL	120/240VAC, Split-Phase, 3-wire + grd
TK-TT2-100-3Y208-FL	120/208VAC, Three-Phase, 4-wire + grd
TK-TT2-100-3Y380-FL	220/380VAC, Three-Phase, 4-wire + grd
TK-TT2-100-3Y480-FL	277/480VAC, Three-Phase, 4-wire + grd

AVAILABLE OPTION

- Stand-Alone Option** (To Be Ordered as a separate Item)
- TT2-FMP Flush-Mount Plate Kit

EMI / RFI FILTER ATTENUATION – MIL STANDARD 220B

Max. Attenuation Frequency
 40 dB @ 100 kHz



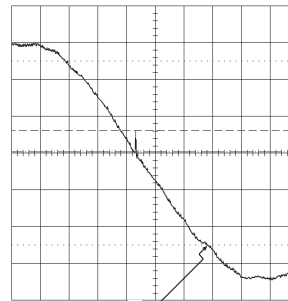
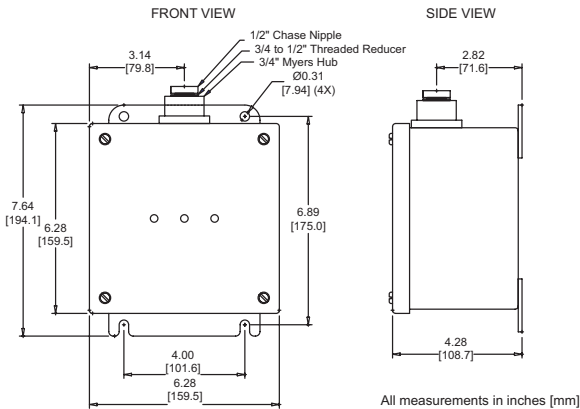

Peak Let-Through Voltage Level - 36V

Reference Level Zero Crossing of AC Sine Wave

For 120/208V Configuration

ANSI/IEEE C62.41.1
Category A1 Ring Wave
2000V, 67A Test Plot

L-N Mode, Dynamic,
180 Phase Angle,
6\" Leads, Positive Polarity
1 msec/div Horizontal
45V/div Vertical

**ANSI/IEEE C62.41.1-2002, C62.41.2-2002, & C62.45-2002
Measured Limited Voltage**

Model Number	System Voltage	System Configuration	Protection Mode	MCOV	ANSI/IEEE C62.41.1-2002, C62.41.2-2002, & C62.45-2002 Measured Limited Voltage			UL SVR
					ETF Models A1 Ring Wave 2kV, 67A 180° Phase Angle	All Models B3/C1 Impulse Wave 6kV, 3kA 90° Phase Angle	All Models C3 Impulse Wave 20kV, 10kA 90° Phase Angle	UL 1449 2nd Edition 2005 Revised Suppressed Voltage Ratings
TK-TT2-100-1P240-FL	240V	1-Phase 3-wire+grnd	L-N	320V	42V	1040V	1660V	800V
			L-G	320V	759V	1067V	1690V	800V
			N-G	320V	721V	961V	1510V	800V
TK-TT2-100-1S240-FL	120/240V	Split-Phase 3-wire+grnd	L-N	150V	36V	590V	970V	400V
			L-G	150V	283V	644V	1160V	400V
			L-L	300V	56V	980V	1490V	800V
TK-TT2-100-3Y208-FL	120/208V	3-Phase WYE 4-wire+grnd	N-G	150V	322V	603V	1100V	400V
			L-N	150V	36V	590V	970V	400V
			L-G	150V	283V	644V	1160V	400V
TK-TT2-100-3Y380-FL	220/380V	3-Phase WYE 4-wire+grnd	L-L	300V	56V	980V	1490V	800V
			N-G	320V	765V	961V	1510V	800V
			L-N	320V	42V	1040V	1660V	800V
TK-TT2-100-3Y480-FL	277/480V	3-Phase WYE 4-wire+grnd	L-G	320V	541V	1067V	1690V	800V
			L-L	640V	63V	1890V	2570V	1500V
			N-G	320V	765V	961V	1510V	800V

All tests performed with 6" (152 mm) lead length, positive polarity.

All voltages are peak values (±10%) measured from the zero reference point at the phase angles referenced above using a 10 μs/div display rate and 500 Mega samples/sec sampling rate. Specifications subject to change without notice, see web site, www.tpssurge.com for latest revisions.